

Victorian Bridge Association Bulletin

November 2017

Editor: Bill Jacobs

THE SOAPBOX Ben Thompson

What is a sport?
Apparently rugby league is not but bridge is.



Recently, the Global Association of International Sports Federations declined Rugby League's application to join. Again. Bridge, on the other hand, has been a full member since 2000.

GAISF is the peak international body for international sporting federations. Among the 92 members are all the Olympic sports as well as a wide variety of non-Olympic sports. Why does the recognition inherent in GAISF membership matter? Because in many countries, insurance, government funding and even just the right to play depend on official international recognition as an organised sport.

If you consider hospitalisation rates and participation rates, relatively dangerous sports like rugby attract a disproportionately large share of government funding in Australia and Victoria.

Waverley bridge club did very well to get some state government funding for its current premises – but to be eligible for the relevant \$500,000 grant, they had to partner up with a sporting club, calisthenics as it happens. Calisthenics is a healthy and challenging activity but so is bridge. Calisthenics has much lower participation than bridge yet was eligible for a huge grant that is way beyond anything bridge could access from a Victorian government grant program purely because calisthenics is recognised as a sport by the AIS.

Do you know a member of Victorian parliament? Try pointing out to them the

state funding inequities, and suggesting they expand their definition of sport to include anything recognised by the international GAISF, not just the local AIS.

PS ... Rugby league commentators were particularly offended that rugby league didn't even get observer status, which was granted to international federations for foot golf, kettleball lifting, pole sports ... and poker.



I'm very pleased to announce the appointment of our new Manager - Andrew Macready-Bryan.



Andrew has been playing, teaching and directing bridge for 40 years. He started young and won the National Youth Teams in 1985. Professionally, Andrew was a teacher before moving into software development and IT management. He is also a passionate and articulate advocate for disability services.

Initially, Andrew will be at the VBA on Mondays, Wednesdays and Thursdays. When you see Andrew - perhaps at the VBA, or at a congress - please make him feel welcome.

I'd like to take this opportunity to thank Bianca Gold, our interim manager, for everything she has done over the last three months at the VBA. She brought great enthusiasm to the role, and I wish her the very best for the future.

(Photo by Michael Rayner, The Weekly Review)

FOR STARTERS

Playing in a Congress Swiss Pairs, you pick up as dealer, with everyone vulnerable:

♠ A962 ♥ A832 ♦ KQ ♣ J83

You open 1♣, which partner announces as showing "2+ clubs". That's strange – you thought you were playing "minimum 3 clubs".

Well, whatever, with the opponents passing, partner responds 1♦, and it is your bid:

LHO	Partner	RHO	You
			1♣
Pass	1♦	Pass	?

Should you rebid 1♥, continuing with up-the-line bidding? Or should you rebid 1NT, showing the balanced shape and HCP range?

Some partnerships play that a 1♥ bid here implies real clubs, at least 4-card length there, and therefore must rebid 1NT.

To do this successfully, they use the Walsh convention (don't ask) then employ a checkback mechanism (either New Minor Forcing or Two-Way Checkback, usually) to subsequently hunt out a 4-4 major suit fit. Yes, there are some complexities to this.

Since you don't even seem to have an agreement on how many clubs are promised for a 1♣ opening, you decide to keep it simple with a 1♥ rebid, and then ...

LHO	Partner	RHO	You
			1♣
Pass	1♦	Pass	1♥
Pass	2♠	Pass	?

What the heck? What's this jump to 2♠ all about, and what do you do next?

We have touched on this in a previous bulletin (December 2016). Most popular is to play a 1♠ rebid as natural and forcing, and 2♠ as 'fourth suit forcing': a hand with enough strength for game, but not sure where.

Your primary objective in responding to fourth suit forcing is to show a stopper in the fourth suit by bidding notrumps. It would be an error to support the spades, as partner shouldn't have spades.

So the somewhat tortuous auction concludes:

LHO	Partner	RHO	You
			1♣
Pass	1♦	Pass	1♥
Pass	2♠	Pass	2NT
Pass	3NT	All pass	

Do you still have the energy for the play? West leads ♣4, and partner tables:

3NT, South	♠ J43
	♥ K97
	♦ A10984
	♣ AQ
	N
♣4 led	S
	♠ A962
	♥ A832
	♦ KQ
	♣ J83

You try the ♣Q from dummy, East wins ♣K, and returns ♣9, West following with ♣2. You win the ♣A, and ...?

... count your top tricks. 1 spades, 2 hearts, 3 diamonds and 2 clubs = 8. The 9th trick can come from several sources, but by far the best, in fact a 100% certainty if you do it right, is diamonds.

If you play ♦KQ, then cross to dummy's ♥K to play the ♦A, you will make an overtrick if the ♦J has dropped. But if it doesn't, your diamonds are dead, because you have no further entry to dummy.

The correct play, which is hard to spot if you haven't seen it before, is to play the ♦K, then *overtake* the ♦Q with the ♦A to continue the suit. You will most probably lose a trick to their ♦J, but in the process set up the suit, guaranteeing 4 diamond tricks (with the ♥K as an entry), and your contract.

The full deal:

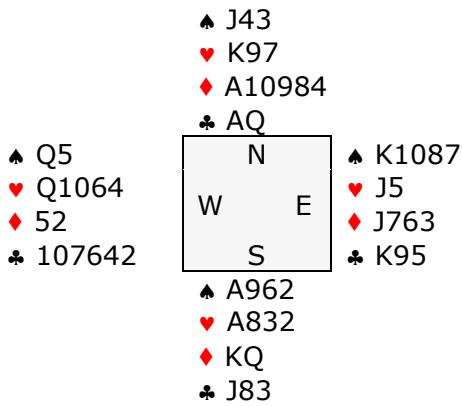

Points to remember:

- Agree with your partner whether the auction 1♣ - 1♦/♥ - 1 major promises a real club suit (at least 4 cards). If not, then fine. But if it does, then you need to play some sort of checkback convention for the auction 1♣ - 1♦/♥ - 1NT.
- After the auction 1♣ - 1♦ - 1♥, have *another* agreement with your partner on the status of a 1♠ or 2♠ rebid by responder. I recommend:
 - 1♠: natural and forcing
 - 2♠: fourth suit forcing to game
- Communications is a big big part of declarer play. Often you have the tricks, but not the means of transport between your hand and the dummy to take them. The overtaking play described here is pretty cool. Another example:

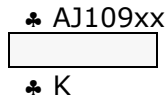

If you're short of entries to dummy, overtake the ♣K with the ace then continue the suit to force out the ♣Q. If your singleton in hand is the ♣Q, the overtaking play is the same.

Even if you had been playing this month's deal in a matchpoint duplicate, where the overtaking play makes an overtrick less likely, it would still be the right play. (Advanced mathematicians can work out the odds.)

TEST YOUR BIDDING

An Unusual Reverse

LHO	Partner	RHO	You
	1♥	Pass	1NT
Pass	2♠	Pass	?

What is going on here? Firstly, partner's sequence constitutes a reverse bid: he has rebid in a new suit that is higher than two of his first bid suit. This guarantees extra strength, at least about 17 HCP, because this auction is driving the level up high.

But it is also an unusual reverse, because partner is bidding a new suit, spades, that you have denied with your 1NT response.

So why is he bidding this way, apparently looking for a spade contract when you've already said you don't have them? Well, he could have a really distributional strong hand with 6 hearts and 5 spades, which means there is quite possibly still an 8-card major suit fit. In this scenario, partner plans to rebid the spades, uncovering the 6-5 shape.

More likely, partner simply has a powerful hand with hearts and spades, and wants to explore the final destination, which could be a partscore or game, and in any of the five possible denominations (suits or notrumps).

This scenario points the way to what you should do now. Quite simply, you have to bid your hand. Bid a long minor, or perhaps show secondary support for one of partner's suits. Or bid notrumps, either 2NT or 3NT, depending on the strength of your hand.

Choose your poison with the following:

- (a) ♠ J4 ♥ 3 ♦ KJ932 ♣ Q8654
- (b) ♠ J4 ♥ 3 ♦ KQ9632 ♣ J654
- (c) ♠ J4 ♥ 3 ♦ KJ932 ♣ A9654
- (d) ♠ J4 ♥ Q3 ♦ KJ932 ♣ 9654
- (e) ♠ QJ4 ♥ 3 ♦ A632 ♣ 98654
- (f) ♠ 654 ♥ - ♦ 96432 ♣ A9654

Solutions over page.

TEST YOUR BIDDING - SOLUTIONS

LHO	Partner	RHO	You
	1♥	Pass	1NT
Pass	2♠	Pass	?

(a) ♠ J4 ♥ 3 ♦ KJ932 ♣ Q8654

2NT. There's no vestige of a fit, no decent minor for you to show, and your hand is minimum in the 6-9 HCP range. All that's left is a 2NT bid saying: "can't help you, pard."

(b) ♠ J4 ♥ 3 ♦ KQ9632 ♣ J654

3♦. Another minimum, but here you have a fine 6-card minor, which you should reveal. Given that partner has the majors, bidding a minor suit here clearly promises at least 6 cards.

(c) ♠ J4 ♥ 3 ♦ KJ932 ♣ A9654

3NT. The same shape as hand (a), but here you have a solid maximum, and should try 3NT. It might not make - this could be a declarer play problem with severe communications issues. But it is worth a try.

(d) ♠ J4 ♥ Q3 ♦ KJ932 ♣ 9654

3♥. Qx is as much as partner can expect from your hearts in this auction: you already denied support with your 1NT bid. If your ♦KJ were the ♦A, you would be within your rights to try 4♥, as the ♠J and ♥Q (in partner's suits) are excellent cards.

(e) ♠ QJ4 ♥ 3 ♦ A632 ♣ 98654

3♠. This could play very nicely in the 4-3 fit, with your hand being used to ruff a heart or two. The ruffing value makes this a better bid than returning to 2NT.

(f) ♠ 654 ♥ - ♦ 96432 ♣ A9654

Pass. You've been a naughty boy (or girl), bidding 1NT with only 4 points. Apparently, you really didn't want to play in 1♥. My partners rebid 2♥ when I try a caper like this, but you have got lucky. Pass partner's forcing bid, on the basis that 2♠ is a better contract than 1♥. This is a setup where two wrongs make a right.

CONGRESS RESULTS**RACV Congress***Swiss Pairs*

- 1 E. Samuels – P. Hollands
- 2 N. Eddie – B. Stean
- 3 K. Frazer – J. Ebery

Albury Congress*Swiss Pairs*

- 1 P. Glover – R. Harman
- 2 S. Klofa – A. Czapnik
- 3 K. Smith – M. Wallis

Swiss Teams

- 1 V. Brockwell, J. Brockwell, T. Gariepy, K. French
- 2 J. Carberry, K. Hart, I. Lisle, V. Lisle
- 3 S. Klofa, A. Czapnik, R. Gallus, S. Weisz

Warrnambool Congress*Swiss Pairs*

- 1 F. Vearing – C. Arul
- 2 J. Coventry – P. Glover
- 3 S. Klofa – R. Gallus

Swiss Teams

- 1 D. Newlands, D. Newland, D. Harley, A. St Clair
- 2 S. Klofa, R. Gallus, G. Bailey, K. Bailey
- 3 B. Jones, P. Jones, D. Read, G. Read

Bairnsdale Congress*Swiss Pairs*

- 1 L. Seychell – C. Manley
- 2 A. Drury – R. Moss
- 3 A. Farthing – J. Kahler

Swiss Teams

- 1 M. Christopher, F. Sundermann, R. Schwabegger, P. Dingwall
- 2 P. Kahler, J. Collins, J. Kahler, A. Farthing
- 3 J. Barbour, G. Nicholson, L. Veenstra, L. Veenstra

Theodor Herzl Congress*Swiss Pairs*

- 1 J. Yang – M. Gurfinkiel
- 2 R. Gallus – S. Weisz
- 3 A. Hegedus – J. Mill

Queen's Slipper Nationwide Pairs

Event 19 (October 7)

3 J. Watson – S. Watson (Bairnsdale)

UPCOMING CONGRESSES & EVENTS

South Gippsland Congress

Saturday 11th November, 12 pm: Swiss Pairs
 Sunday 12th November, 10 am: Swiss Teams

Venue Dakers Centre
 23 Smith St, Leongatha

Contact: Neville Chapman, 0427 392 979

Enter: <http://bridgeunlimited.com>

Bridge at Tivoli Congress

Saturday 25th November, 10 am: Butler Pairs
 Sunday 26th November, 10 am: Swiss Pairs

Venue VBA Clubrooms
 131 Poath Rd, Murrumbeena

Contact: Leeron Branicki, 0412 884 446

Enter: <http://bridgeunlimited.com>

Dendy Park Congress

Sunday 3rd December, 10 am: Swiss Pairs

Venue Dendy Park clubrooms
 Breen Drive, Brighton

Contact: Boris Tencer, 0414 353 996

Enter: <http://waverleybridgeclub.com.au>



BEGINNER LESSONS

Knox Bridge Club

Beginner bridge class at Knox is on Thursday mornings from 10 am to 12 pm.

Please contact Stella Hammond, ABF-Accredited Bridge Teacher, on 8740-3520 for more details.

RECENT MASTER PROMOTIONS

State

Sally Baird	Sale
Pat Besley	Rye Beach
Virginia Cameron	Royal South Yarra
Michael Dooley	Phillip Island
Richard Giles	Ballarat
David Hill	Melbourne
Lawna Monks	Yarra Valley
Jan Page	Sale
Susan Rennie	Waverley
Fritz Riedacher	Bairnsdale
Akiko Stark	Waverley
Rose-Ann Stewart	Mornington
Kevin Taylor	Traralgon
James Thomas	Waverley
Robin Tuttleby	Melbourne
Kathleen Zarebski	Bayside

*State

Neville Chapman	South Gippsland
Rodney Grigoleit	Dromana
David Louden	Yarra Valley
Tek Marko	Moonee Valley
Paul Waylen	Phillip Island

National

Lynn Moodie	Dromana
Martin Symons	VBA
Nafty Van Der Hoek	VBA

*National

Margaret Glover	Geelong
Mal Robertson	Bairnsdale

**National

Patricia Dungey	Bendigo
John Moir	Yarra Valley

Life

Jillian Lawrence	Dendy Park
------------------	------------

Bronze Life

Pam Dingwall	Lakes Entrance
Margaret Morgan	Rye Beach

Silver Life

Dorothy Stewart	Yarra Valley
Faye Symons	Bendigo

Gold Life

Sue Read	Yarra Valley
John Yang	VBA

Gold Grand

Shirley Collins	Waverley
-----------------	----------

Vu-graph quotes from Edgar Kaplan

"When partner asks for help in a side suit and you respond positively with three small, it is an insult to your partner. And if he's well-built and hefty, it is a poor idea to insult him."

LEAD OUT OF TURN



It's usually something for the Director to sort out. But not in this case.

Here the lead belongs to Hector, a Seeing Eye Dog In-Training with his bridge-playing carer, Eveline Fallshaw.

As with all visitors to Moonee Valley Bridge Club, Hector was made to feel very welcome.

... *Graham Morris*

NEWS FROM THE VBA COUNCIL

VBA Annual General Meeting

The AGM will be held on Monday November 20th commencing at 6.30 pm, at the VBA Clubrooms in Poath Rd Murrumbena.

Several weeks ago, the VBA called for nominations for the positions of Special Councillor. At the close of nominations, two nominations had been received – from Richard Giles representing Western Zone, and from Rob Quirk representing the “Metro near VBA” zone. As per the regulations, these nominees will be declared elected at the AGM.

Special Councillor positions for both the Eastern Region Zone and Metro Arc remain vacant, and clubs and members in those regions who may be interested in joining the council are invited to contact the secretary for further information on becoming a Special Councillor.

Commonwealth Nations Bridge Championships

The VBA has been invited to field a team at the 2018 Commonwealth Nations Bridge Championships (CNBC) in the Trans-National Championship Category which will be contested at the Gold Coast from 14-18 February 2018.

The VBA is inviting nominations from eligible teams.

If more than one team nominates, the team selected will be based upon the following order and conditions:

- 2017 Pennant winners,
- 2017 open/seniors/womens state teams in that order,
- 2017 country teams champions,
- Team with the most 2017 VQPs at the closing date.

No subsidy or support will be provided except official recognition; ie the teams will be responsible for payment of all costs including the entry fee of \$1200 per team.

Full details are available on the VBA website at <http://vba.asn.au/5th-commonwealth-nations-bridge-competition/>

Changes to VBA Council

Mr Dale Sheather has resigned from the council due to work commitments. The VBA thanks Dale for his work on both the Council and Match & Tournament Committee over the past few years.

Ms Helen McAdam has also announced her intention to step down at this year's AGM after three years as the Eastern Zone representative. The VBA also thank Helen for her contribution, and in particular for her work on developing a Grant Writing Guide. Helen will continue in her role as a member of the VBA's Congress Disciplinary and Ethics Committee.

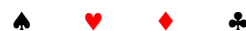

SECOND HAND HIGH
Bill Jacobs

They say that those who ignore history are condemned to repeat it. Players who sat West in the following two deals from a Mixed Pairs event some years ago may have had a great opportunity to learn from history:

Dir: South ♠ 43
 Vul: E/W ♥ 10765
 ♦ 74
 ♣ AJ1098

♠ J2 ♥ A43 ♦ K10862 ♣ K74	N W E S	♠ KQ10976 ♥ - ♦ QJ93 ♣ Q62
------------------------------------	--------------------------	-------------------------------------

♠ A85
 ♥ KQJ982
 ♦ A5
 ♣ 53

West	North	East	South
			1♥
Pass	2♥	2♠	4♥
D'ble	Pass	Pass	Pass

Against 4♥ doubled, West led the spade jack to South's ace, and a club was played at trick two.

The winning play is "second hand high" – go in with the king! This play forces South to win the club ace, and now there is no fast entry to enjoy the third round of clubs for a diamond discard. Indeed, if West does find the king play, South will likely duck it, and take a finesse on the second round – down two!

West actually followed with a low club, East won the queen and played a diamond, but declarer got it right, winning the diamond, taking a second club finesse and pitching the diamond loser on the club ace. Making four.

Interestingly, if East declares 4♠ and South happens to lead a club, then declarer must make the same "second hand high" play – the king to separate the defence from their second club winner. How symmetrically delightful.

Well, West can perhaps be excused for missing this play, but only a few deals later:

Dir: West ♠ 853
 Vul: nil ♥ Q63
 ♦ 763
 ♣ AJ106

♠ AQ107 ♥ J ♦ QJ1098 ♣ Q43	N W E S	♠ 642 ♥ 10542 ♦ K54 ♣ K92
-------------------------------------	--------------------------	------------------------------------

♠ KJ9
 ♥ AK987
 ♦ A2
 ♣ 875

West	North	East	South
1♦	Pass	1♥	Pass
1♠	Pass	2♦	2♥
Pass	Pass	3♦	Pass
Pass	3♥	All Pass	

Against 3♥, West led the diamond queen, South let that win, won the second diamond, and played a club ...

West must learn from history (and the bridge gods have been kind, making the key suit clubs again as an aide memoire) and go in with the queen.

But West actually played a low club – and the play was simple. The 10 forced the king, and declarer was able to then draw trumps with a finesse, and repeat the club finesse to discard a spade loser on the long club. The defence didn't have the communications to take three fast spade tricks.

Note that in both examples, going in with the club honour is relatively safe. On the first hand, South would obviously be finessing anyway if he owns the queen; and similarly on the second hand, one would expect South to finesse the opening bidder for the queen should he have started with ♣Kxx.

Sydney Spring Nationals

Well done to Justin Mill and Jamie Thompson for their semi-final appearances at the recent Sydney Nationals Open Teams.

And congratulations (and commiserations) go to David Morgan, who with Canberran Stephen Fischer, narrowly lost in the final of that event.

ALL ABOUT ALERTING

Alerting is about drawing the opponents' attention to your side's unusual bidding. It causes a tremendous amount of angst around the bridge clubs of Australia.

The rules of alerting are in a set of regulations issued by the Australian Bridge Federation. The document runs to 11 pages, so I'll save you some trouble ...

Using written bidding you alert *your partner's* unusual bid by circling it and saying "Alert". If using bidding boxes, get out and display the Alert card, and also say "Alert". Don't explain anything: wait to be asked.

The definition of an "unusual bid" is somewhat gray, but the general principle is that if a bid's meaning is not what it sounds like, then it should be alerted. Usually this involves bidding a suit that does not show length in that suit, or bidding notrumps when it does not indicate a desire to play in notrumps. It also includes a natural bid that has an unexpected HCP range. Examples:

- Transfer bids
- Unusual Notrump or Lebensohl
- Multi 2♦ opening
- 'Pass or correct' bids
- Weak jump responses
- Inverted minor raises

Self-alerting bids

Some bids are defined as self-alerting, meaning they do not require an actual alert, as they are "obviously unusual". These are:

- Doubles and redoubles
- All bids above 3NT (except unusual high level openings, eg NAMYATS)
- Cue bid of opponents' suit
- 2♣ response to a 1NT opening bid

Asking

You can ask about any alerted bid, or unalerted bid for that matter, but only at your turn to bid or play. Most people only ask if the answer may affect their upcoming bid or play, but it is entirely up to you whether or not you ask.

When asking, ask in general terms, not using leading questions. So say: "what does 2♣

mean?", not "does 2♣ show clubs?" (which could be interpreted as code for 'I have clubs'). At the end of an auction that had multiple alerts, say: "explain the auction please", rather than asking about one specific alerted bid.

Answering

You are required to explain your partnership agreements, nothing more. If you're not sure what partner's bid means or have forgotten your agreements, try not to guess. Just say: "I don't know" or "I don't remember". (In some circumstances, the director may send you away from the table whilst your partner explains his own bid.)

If you haven't discussed a bid, say it is undiscussed. Again, do not offer a possible explanation, or how you are going to take it.

Partner fails to alert, mis-alerts, or mis-explains

Happens all the time, right? You must stay shtum for the moment. Then ...

At auction's end, with your side declaring:

Before the opening lead, draw your opponents' attention to the problem. Explain what you think went wrong.

If your side ends up defending:

You can say nothing until the end of the play, at which point you should identify the issue.

In both situations, it may be wise to call the director, certainly if there is any possibility that the opponents were damaged by the problem.

Pre-alerting

At the start of each round, you should pre-alert your opponents to any unusual convention that they may need to arrange a defence against. Main examples are:

- Transfer responses to 1♣
- Very unusual 2-level openings (eg 2NT for the minors) ... the Multi scheme does not need a pre-alert, as it's so prevalent
- A system other than some form of Standard American: eg Precision, Acol